

MAGNETIC AERATION SYSTEM FOR FRAC, STEEL, AND POLY TANKS (PATENT PENDING)

Remtech's **FRACAIR** and **MAGAIR** (Magnetic Aeration System) is a cutting-edge solution for rapidly converting frac tanks, steel, poly, and stainless tanks into temporary or permanent wastewater, water, stormwater, groundwater, or dewatering treatment systems. With proprietary **magnetic anchoring technology**, aeration and mixing systems can be rapidly deployed **without drilling, welding, or tank modifications**—perfect for rental tanks, short or long-term projects during plant expansions, cleanings, repairs or new treatment processes.

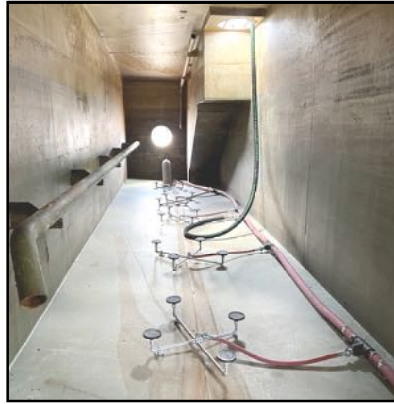

FRACAIR Magnetic Aeration Wastewater and Water Treatment System



Blower Side Mount Tank Option

KEY BENEFITS:

- ✓ **Numerous Waste Stream Treatment Applications** - Domestic & Industrial Wastewater, Water Treatment, Landfill Leachate, Stormwater, Dewatering Treatment, Oil Field Production Wastes, Contaminated Groundwater & PFAS.
- ✓ **Fast Installation** – Easily installed through 20" manholes and are secured by **powerful magnets**.
- ✓ **Versatile Treatment Applications** – For aerated grit chambers, equalization, solids mixing, air stripping, oil/water separators, biological treatment, flocculation, dissolved air floatation, and neutralization systems.
- ✓ **Adjustable & Performance Optimization** – Variable airflow, bubble sizes, and retention times optimize treatment.
- ✓ **Energy Savings Up to 80%** – Blower aeration significantly reduces energy costs compared to mechanical mixing.
- ✓ **Modular & Scalable** – Installable in single or multiple tanks for flow rates exceeding **200,000 GPD**.
- ✓ **Odor & Emission Control** – Air inlet flanges facilitates off-gas capture and treatment...carbon or biobed treatment.

FLEXIBLE EQUIPMENT & CUSTOMIZATION:

- ✓ **Tank Compatibility:** Fits 5,000, 10,000, 21,000-gallon, and larger tanks.
- ✓ **Air Supply Options:** Regenerative or rotary lobe blowers, trailer-mounted compressors or plant air.
- ✓ **Durable Materials:** Materials of construction include schedule 80 PVC, stainless steel, and EPDM elastomers for wastewater chemical compatibility.
- ✓ **Advanced Diffuser Technology:** Choice of disc, sintered, or wide band stainless bubble diffusers (fine, medium, or coarse).
- ✓ **Scalable Blower Systems:** 5 to 10 HP blowers efficiently aerate individual or multiple tanks.

MAGNETIC ANCHORING FOR POLY OR STAINLESS TANKS:

For **poly or stainless tanks**, systems can be securely anchored using 16 mil ferrous plates mounted in tank pads allowing powerful magnets to provide stable aeration system tank anchoring—even through thick tank bottoms.

EXPANDABILITY & ADVANCED TREATMENT OPTIONS:

Easily integrate modular tertiary treatment systems such as:

- ✓ **Screening & Clarification**
- ✓ **Filtration & Dissolved Air Flotation (DAF)**
- ✓ **Serpentine Neutralization & Flocculation**
- ✓ **Sludge Dewatering & Advanced Wastewater Treatment**

READY FOR RAPID DEPLOYMENT:

Remtech's FRACAIR Magnetic Aeration System delivers **cost-effective, plug-and-play treatment solutions**—ideal for plant expansions, temporary installations, or emergency wastewater treatment.

NO PERMANENT ALTERATIONS. MAXIMUM EFFICIENCY. RAPID DEPLOYMENT:

Get started today! Contact Remtech for a solution to your treatment needs by filling out our eform on our website www.remtech-eng.com under *Environmental Equipment* or calling 800-377-3648 x 4.



Remtech's *FRACAIR* Magnetic Aeration System for Frac Tanks

(for Blower, Plant or Compressor Air Supply)
(Patent Pending)

Remtech's *FRACAIR* system can be supplied with a pressure reducer and flow regulator for plant or compressor air. Open top manhole or closed flange air supply connections available for off-gas treatment by activated carbon, biobeds, or other treatment technologies.



Compressor Air Control Valve & Anti-Siphon Light Cage



Remtech 10 Hp FPZ Two-Stage Regenerative Blower



Compressor Air Pressure Reducer and Air Flow Regulator



Sealed Flange Air Injection for Off-Gas Treatment



FracAir fits on 4 ft x 4 ft pallet



Air Inlet Anti-Siphon Manhole Light Cage Mounted on Frac Tank

SAMPLE MOBILE FRAC TANK TREATMENT SYSTEMS

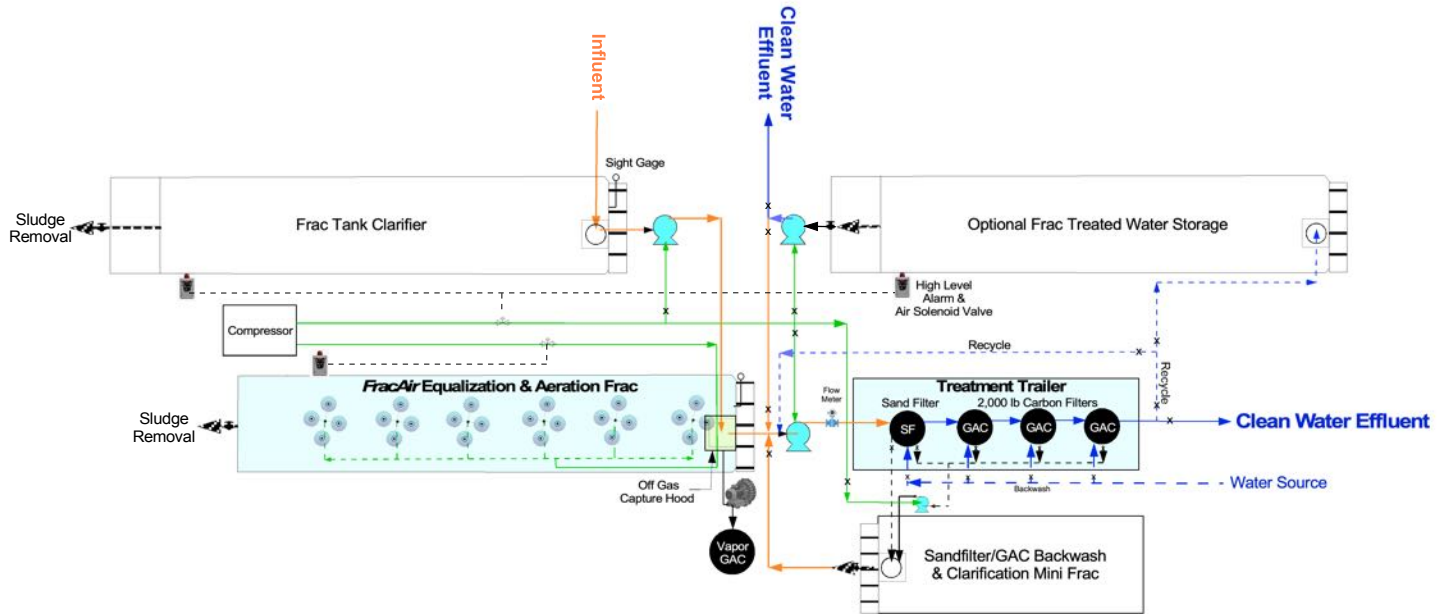

MOBILE PFAS TREATMENT SYSTEM WITH REMTECH FRACAIR MAGNETIC AERATION SYSTEM

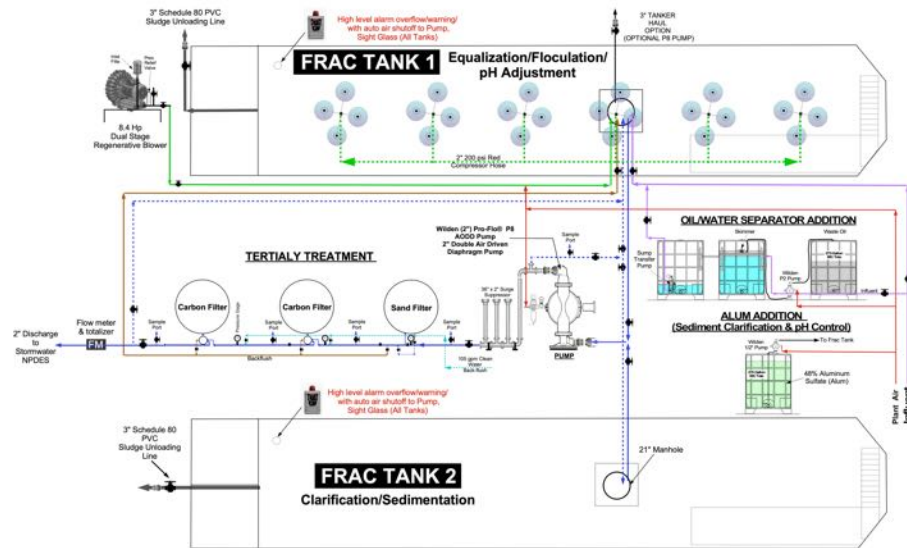

TEMPORARY REMTECH FRAC TANK MAGNETIC AERATION TREATMENT SYSTEM



200 North Cobb Parkway, Suite 208, Marietta, Georgia 30062
770-427-7766 x 203, www.remtech-eng.com