

Remtech's Magnetic Frac Tank (FRACAIR) Wastewater and Water Treatment Aeration System (Patent Pending)

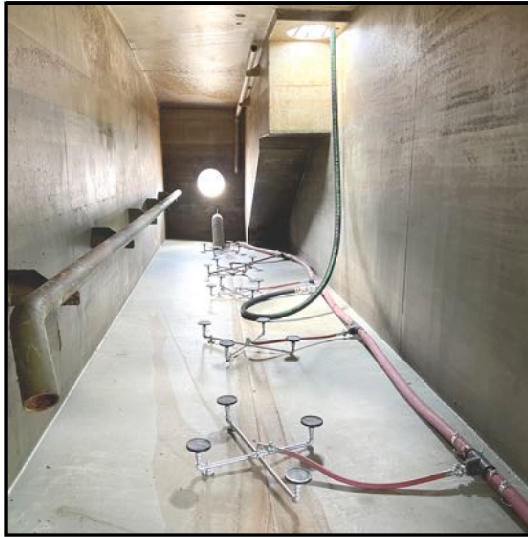

FRACAIR Magnetic Aeration Wastewater and Water Treatment System

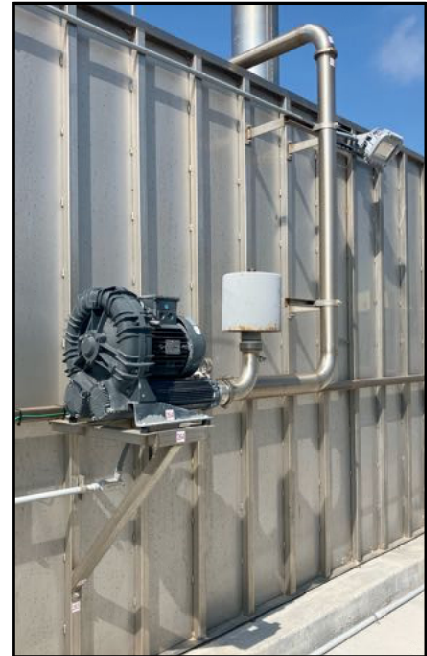

Blower Side Mount Tank Option

Remtech has developed a proprietary magnetic wastewater and water treatment system for domestic and industrial wastewater and contaminated groundwater. FRACAIR converts conventional FRAC TANKS into treatment systems with life spans up to 30+ years.

Wastewater applications include industrial, municipal, oil field production, septic tank, landfill leachate, and contaminated groundwater. The [FRACAIR Magnetic Aeration System](#) provides adjustable airflow and retention times to create aerated grit chambers, equalization basins, flocculators, clarifiers, and biological treatment systems out of standard frac tanks.

FRACAIR Features:

- ✓ Installs quickly in 10,000-to-21,000-gallon frac tanks with 20" or larger manholes.
- ✓ Materials of construction are selected based on wastewater compatibility and desired life span include - epoxy coated steel, stainless steel, HPDE, EPDM, PVC, and ceramic magnets.
- ✓ Uses 24-100 lb magnets with 2,400 pounds of diffuser anchoring.
- ✓ Fine, medium or coarse EPDM disc or stainless sintered diffusers are available for mixing or aeration.
- ✓ Supports flow rates up to 200,000 gpd with multiple frac tanks.
- ✓ Blower ground or frac tank side mount options available.
- ✓ Sealed flange air injection is available for off gas odor treatment with activated carbon or other gas treatment.

FRACAIR System Enhancements:

- ✓ 7 to 10 Hp regenerative blowers reduce Hp requirements over mechanical mixing by up to 80% per frac tank.
- ✓ Regenerative blower pressures exceed 170" of water.
- ✓ Regenerative blowers are less expensive, run quieter, require less maintenance, and operate without weather enclosures compared to rotary lobe blowers.

FRACAIR Advanced Treatment Options:

- ✓ Serpentine neutralization, filtration (multi-media, carbon, ultrafiltration, reverse osmosis), disinfection, DAF, sludge dewatering, and more....

For more information, view a short [YouTube Video located at https://youtu.be/iPHvSfxNyll](https://youtu.be/iPHvSfxNyll) or contact Remtech at remtech-eng.com and click on Store, Magnetic Aeration System.



Remtech's *FRACAIR* Magnetic Aeration System for Frac Tanks (for 185 cfm Trailer Mounted Compressor Air Supply (Patent Pending))



Compressor Air Control Valve & Anti-Siphon Light Cage



Air Pressure Reducer and Air Flow Regulator



Sealed Flange Air Injection for Carbon Off-Gas Treatment



FracAir fits on 4 ft x 4 ft pallet



Anti-Siphon Manhole Light Cage Mounted on Frac Tank

Remtech's FRACAIR system can be supplied with a pressure reducer and flow regulator for supplied air from high pressure tow behind compressors or plant air.

Sintered diffuser heads can be rotated to keep solids in suspension.



200 North Cobb Parkway, Suite 208, Marietta, Georgia 30062
770-427-7766 x 203, www.remtech-eng.com

SAMPLE MOBILE FRAC TANK TREATMENT SYSTEMS

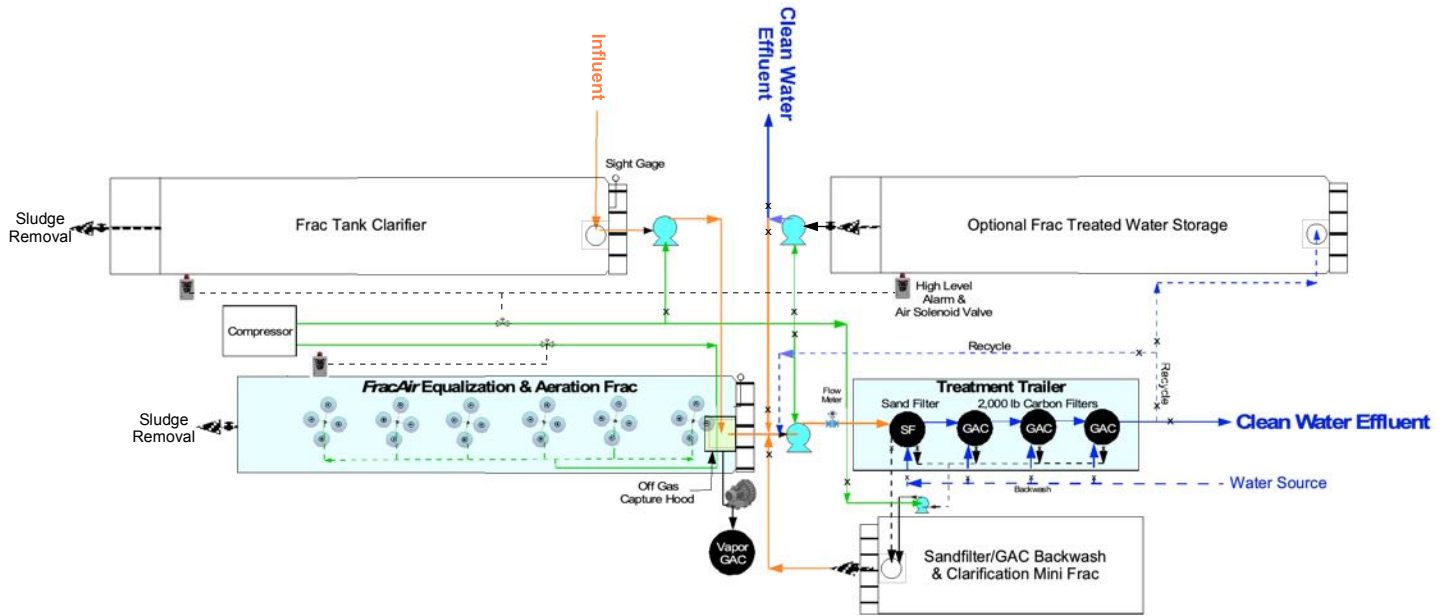

**MOBILE PFAS TREATMENT SYSTEM WITH REMTECH
FRACAIR MAGNETIC AERATION SYSTEM**

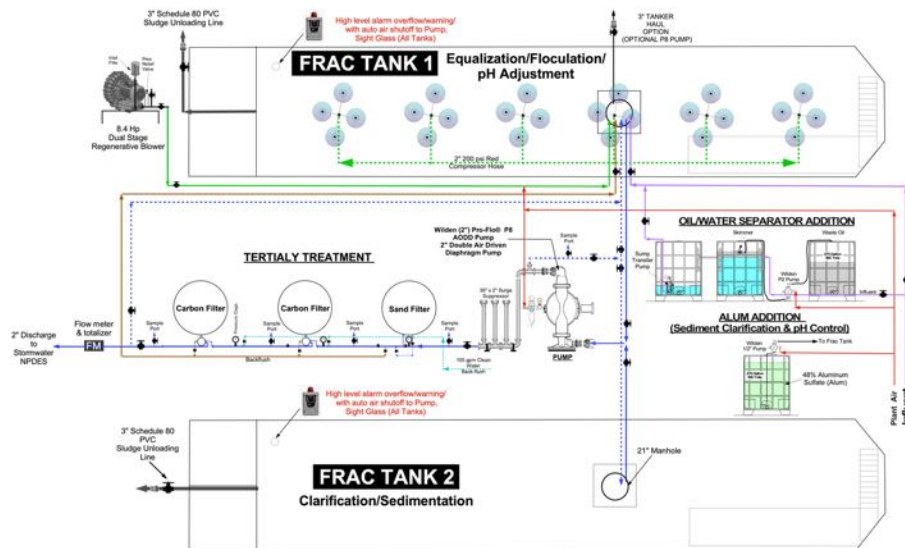

TEMPORARY REMTECH FRAC TANK MAGNETIC AERATION TREATMENT SYSTEM



200 North Cobb Parkway, Suite 208, Marietta, Georgia 30062
770-427-7766 x 203 , www.remtech-eng.com