

Remtech's Frac Tank Mobile Water and Wastewater Treatment Systems with *FRACAIR* Magnetic Aeration (Patent Pending)



Remtech FRACAIR Magnetic Aeration System with Membrane Disc or Sintered Diffusers

Remtech has developed a proprietary magnetic modular wastewater treatment system that converts conventional rental FRAC TANKS into temporary mobile water and wastewater treatment systems during plant cleaning, repairs, or expansions. The [FRACAIR Magnetic Aeration System](#) provides adjustable airflow and retention times, enabling creating aerated grit chambers, equalization basins, flocculators, clarifiers, biological treatment, activated sludge, and sludge thickeners for biological or physiochemical treatment.

FRACAIR Features:

- ✓ Converts frac tanks or steel tanks into temporary treatment systems. Installs quickly in 10,000-to-21,000-gallon frac tanks via 20" manholes.
- ✓ Uses 80 lb magnets to secure diffuser clusters and flexible trunk and branch lines.
- ✓ Fine or coarse diffusers reduce Hp requirements over mechanical mixing by up to 80% per frac tank.
- ✓ Supports flow rates up to 200,000 gpd with parallel connections with up to 10 frac tanks.
- ✓ Counterweighted anchors are available for concrete basins, poly tanks, and lined basins.

FRACAIR System Enhancements:

- ✓ Two stage 5 to 10 Hp regenerative or rotary lobe blowers provide aeration if plant air is unavailable for up to three frac tanks.
- ✓ Piping and diffuser options range from PVC to stainless steel depending on wastewater compatibility
- ✓ Scalable to larger steel or membrane-lined tanks for flow rates exceeding 200,000 gpd.

FRACAIR Advanced Treatment Options:

- ✓ Serpentine neutralization, filtration (multi-media, carbon, ultrafiltration, reverse osmosis), disinfection, DAF, sludge dewatering, and more....

For more information, view a short [YouTube Video located at](#) <https://youtu.be/iPHvSfxNyll> or contact Remtech at remtech-eng.com and click on Store, Magnetic Aeration System.



Anti-Siphon with Check Valve Inlet Cage Prevents Water Backflow to Blower



FracAir fits on 4 ft x 4 ft pallet



Remtech's 5 Hp Single Phase Rotary Lobe Blower with Weather Enclosure



Remtech's 7.5 Hp 3-phase Rotary Lobe Blower with Weather Enclosure



200 North Cobb Parkway
Suite 208
Marietta, Georgia 30062
770-427-7766 x 203 (phone)
770-427-7001 (fax)
website: www.remtech-eng.com

Remtech's *FRACAIR* Magnetic Aeration System for Frac Tanks (for 185 cfm Trailer Mounted Compressor Air Supply (Patent Pending))



Compressor Air Control Valve & Anti-Siphon Light Cage



Air Pressure Reducer and Air Flow Regulator



Anti-Siphon Light Cage Mounted on Frac Tank



FracAir Ships on 4 ft x 4 ft pallet



Sintered Diffusers Can be Rotated for Bottom Mixing

Remtech's *FRACAIR* system can be supplied with a pressure reducer and flow regulator for supplied air from high pressure tow behind compressors or plant air.

Sintered diffuser heads can be rotated to maintain solids in suspension.



200 North Cobb Parkway
Suite 208
Marietta, Georgia 30062
770-427-7766 x 203 (phone)
770-427-7001 (fax)
website: www.remtech-eng.com

SAMPLE MOBILE FRAC TANK TREATMENT SYSTEMS

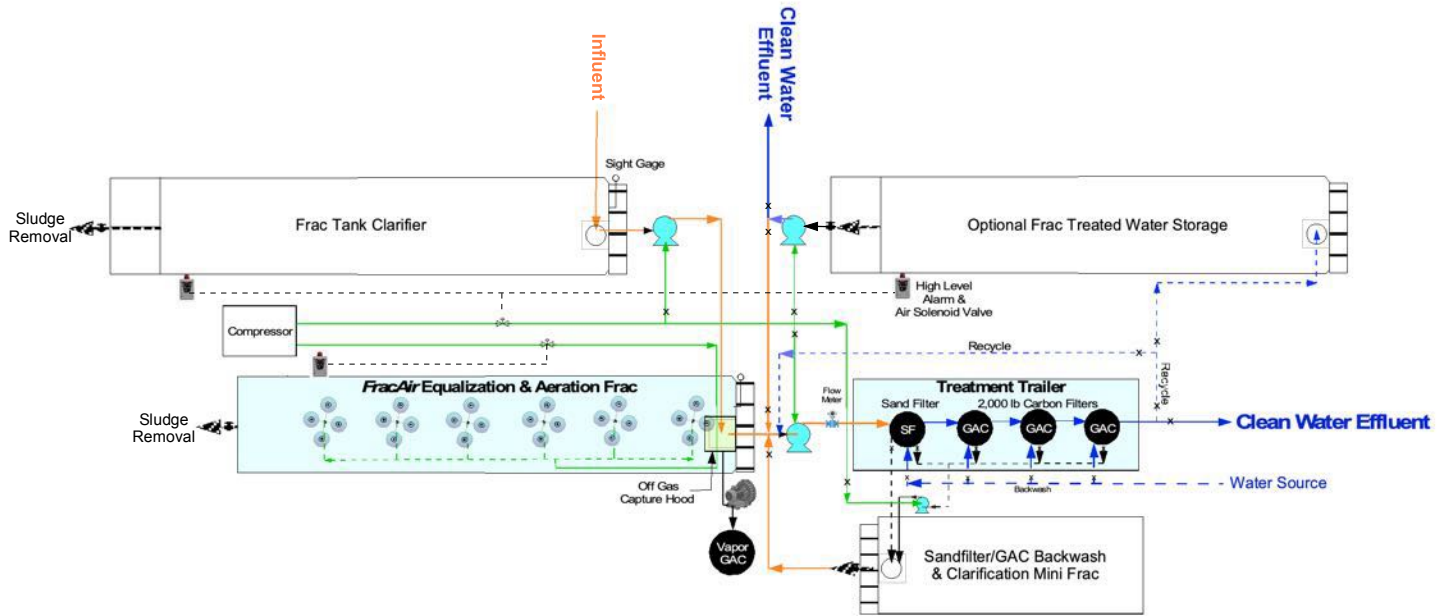

MOBILE PFAS TREATMENT SYSTEM WITH REMTECH FRACAIR MAGNETIC AERATION SYSTEM

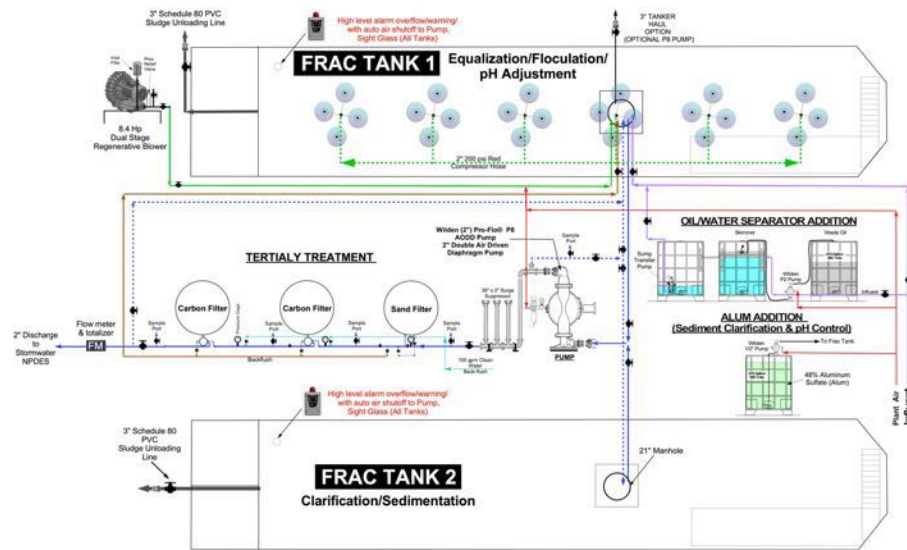

TEMPORARY REMTECH FRAC TANK MAGNETIC AERATION TREATMENT SYSTEM



200 North Cobb Parkway
 Suite 208
 Marietta, Georgia 30062
 770-427-7766 x 203 (phone)
 770-427-7001 (fax)
 website: www.remtech-eng.com